

Esempio di applicazione / Example of application

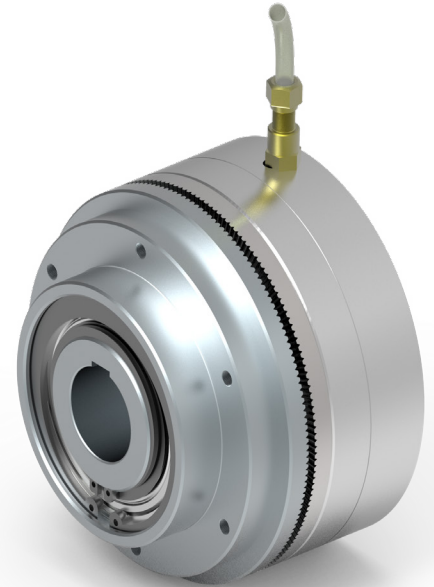

Dimensioni / Dimension

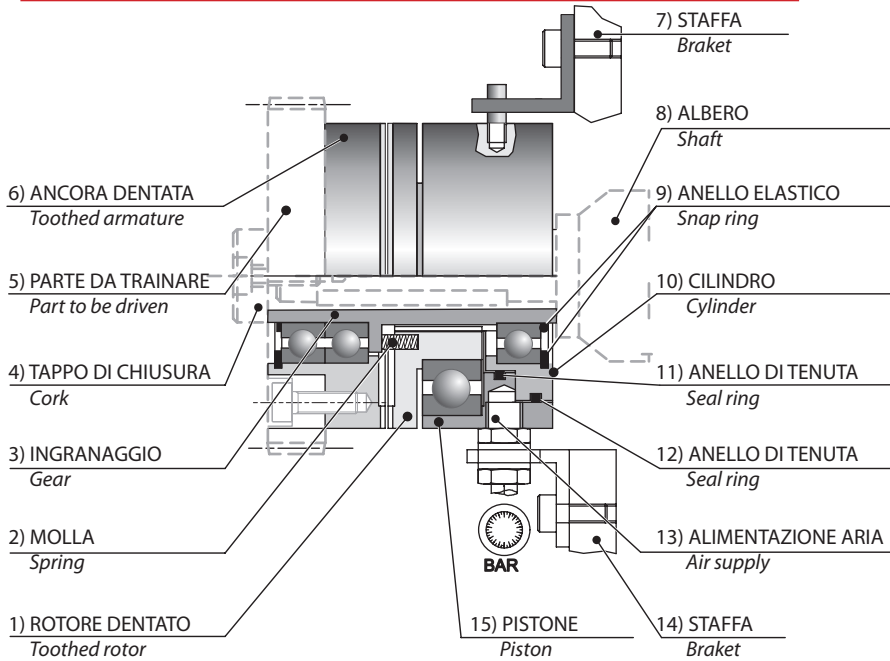
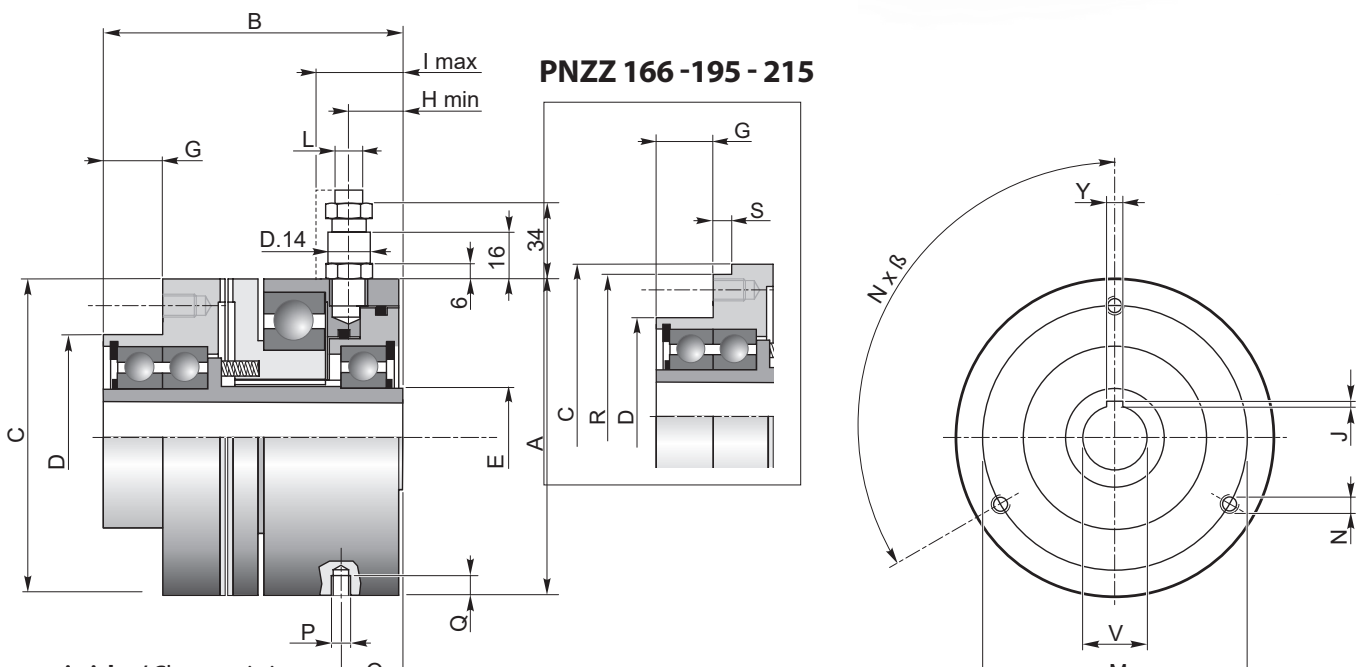

Caratteristiche / Characteristics

TAGLIA SIZE	Coppia Nom. Statica Nominal Static Torque CU 1)	Pressione Pressure	nmax	Z 	
	Nm	bar	rpm		
PNZZ72	50	6	3500	108	1.2
PNZZ82	100	6	3500	120	1.8
PNZZ95	140	6	3000	130	2.3
PNZZ114	170	6	2800	144	4
PNZZ124	280	6	2500	168	5
PNZZ134	400	6	2500	168	5.6
PNZZ152	580	6	2000	180	9.2
PNZZ166	780	6	1800	180	10.8
PNZZ195	1350	6	1500	212	18
PNZZ215	2150	6	1300	240	24
PNZZ240	4500	6	1200	333	34
PNZZ280	6500	6	1000	410	50

1) Selezione del valore di coppia vedere pag. / Selection the torque value see page

p.45

Innesto a denti pneumatico

Pneumatic toothed clutch

Codice d'ordine / Order code

TIPO E TAGLIA TYPE AND SIZE	Ø ALBERO Ø SHAFT
	C
PNZZ95	2
PNZ72	1
...	2
...	3
PNZ280	4

Albero / Shaft

		PNZZ..																																												
C	TAGLIA SIZE	72			82			95			114				124				134				152				166				195				215				240				280			
	CODICE CODE	1	2	1	2	3	1	2	3	1	2	3	1	2	3	4	1	2	3	4	1	2	3	4	1	2	3	4	1	2	3	4	1	2	3	4	1	2	3	4	1	2	3	4		
	øV	12	15	12	15	18	19	20	22	19	20	25	25	30	32	35	25	30	32	35	30	35	40	45	35	40	45	50	45	50	55	60	55	60	65	70	65	70	75	80	75	80	85	90		
	Y	4	5	4	5	6	6	6	6	6	8	8	8	10	10	8	8	10	10	8	10	12	14	10	12	14	14	14	16	18	16	18	18	20	18	20	20	22	20	22	22	25				
	J	1.8	1.3	1.8	2.3	1.7	2.8	2.8	1.7	2.8	2.8	3.3	3.3	3.3	3.3	3.2	1.3	3.3	3.3	3.3	3.3	3.3	3.3	3.3	3.3	3.3	3.8	3.8	3.8	3.8	4.4	4.4	4.4	4.4	4.4	4.4	4.4	4.4	4.4	4.4	9.4	1.4	9.5	4.5	4.4	1
	n° Cave/ n° Key	1	1	1	1	1	1	1	1	1	1	1	1	1	1	1	1	1	1	1	1	1	1	1	1	1	1	1	1	1	1	1	1	1	1	1	1	1	1	1	1	1	1	1	1	1

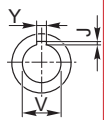

Dimensioni/ Dimension

TAGLIA SIZE	A	B	C	D (-0.01/-0.03)	E	G	H Min	I Max	L	M	N	N x β°	O	P	Q	R	S
PNZZ72	72	71	72	48	20	19	11	15	8	59	M5	3 x 120°	13	M6	6	-	-
PNZZ82	82	78	82	55	25	16	13	17	8	68	M6	3 x 120°	15	M6	8	-	-
PNZZ95	95	83	95	65	30	18	14	18	8	82	M6	3 x 120°	15	M6	8	-	-
PNZZ114	114	93	114	72	35	20	15	19	8	88	M6	6 x 60°	18	M8	6	-	-
PNZZ124	124	98	124	88	45	20	15	19	8	102	M6	6 x 60°	21	M8	6	-	-
PNZZ134	134	101	134	88	45	22	15	19	8	108	M6	6 x 60°	20	M8	8	-	-
PNZZ152	152	112	152	102	60	23	17	21	8	120	M6	6 x 60°	20	M8	8	-	-
PNZZ166	166	113	166	112	65	22	17	21	8	135	M8	6 x 60°	21	M8	8	150	16
PNZZ195	195	129	195	132	75	25	19	23	8	155	M8	6 x 60°	23	M8	10	178	15
PNZZ215	215	146	215	145	85	35	19	28	8	180	M10	6 x 60°	24	M8	12	208	20
PNZZ240	240	165	240	179	100	41	21	29	8	200	M10	8 x 45°	28	M8	12	-	-
PNZZ280	280	185	280	210	120	57	26	33	8	250	M12	8 x 45°	33	M8	12	-	-